

Seitenkanalverdichter DHB-400

direktangetrieben – Laufrad, Gehäuse und Motorgehäuse hergestellt aus Aluminiumguss, inkl. 2x Schalldämpfer für Ein- & Austritt

Vacuum selection diagram curve

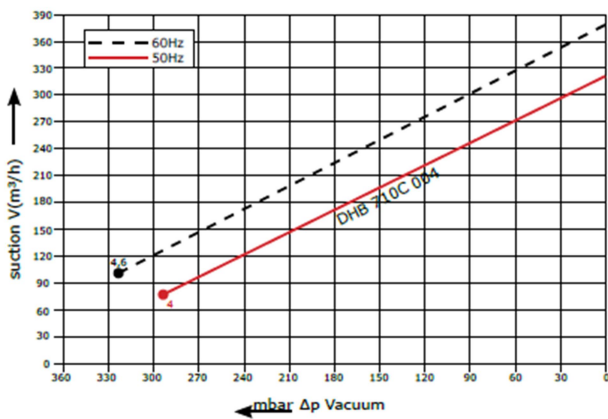

Compressor selection diagram curve

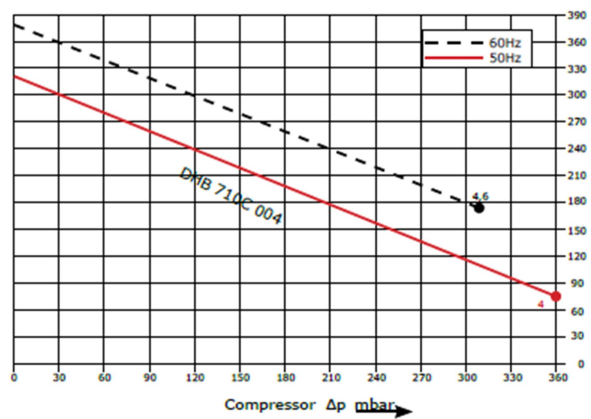

Lajac blower installation drawing

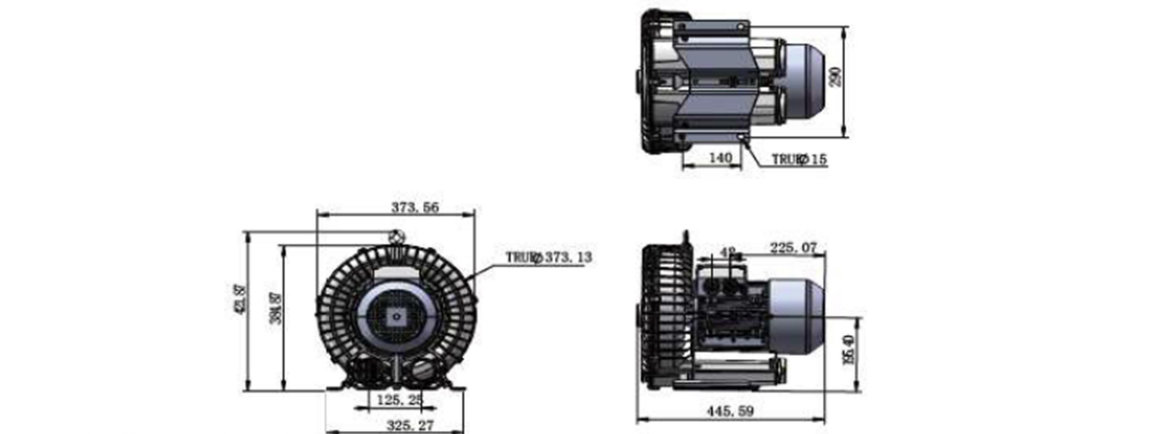

Lajac blower installation parameter

Model	Frequency HZ	Output KW	Voltage V	Current A	Airflow m³/h	Pressure		Noise dB(A)	Weight kg
						Vacuum mbar	Compressor mbar		
DHB 710C 004	50	4	345-415Δ/600-720Y	9,0Δ/5,2Y	318	-290	360	69	40
	60	4,6	380-480Δ/660-720Y	9,0Δ/5,5Y	376	-320	310	72	40