

# Operating and Maintenance Instruction for Pneumatic Slide Valves as at September 2006

## Content:

1. Safety guidelines
2. Design
3. Use
4. Installation
5. Maintenance
6. Technical data
7. Spare part list

## 1. Safety Guidelines

For installation and putting into operation the current Health and Safety Regulations applicable for the operating location are to be observed decisively.

The slide valve has to be installed properly, so that no danger spot with fixed or movable parts of the environment appears while opening and closing.

### Caution crushing hazard!

A protection shelter for covering the slide valve sheet is available for extra charge. Before starting maintenance and repair work it is absolutely necessary to disconnect the slide valve from mains connection and compression air system. Automatic control of the slide is possible!

## 2. Design

The shell is made of two casing halves bolt together.

Up to a nominal diameter of 200 mm two sealing rings are inserted in each casing half (see illustration). From a nominal diameter of 225 mm up in each casing half one sealing ring is riveted.

Up to a nominal diameter of 200 mm a pneumatic cylinder is installed.

From a nominal diameter of 225 mm up the slide valve is operated by two pneumatic cylinders with a diameter of 25 to 50 mm.

The slide valve operating by a 5/2 selector valve with spring return is standard equipment. Special design is available on request.

Installation of proximity switches directly on the cylinder for positioning is possible. The switches are activated by a magnet in the cylinder piston.

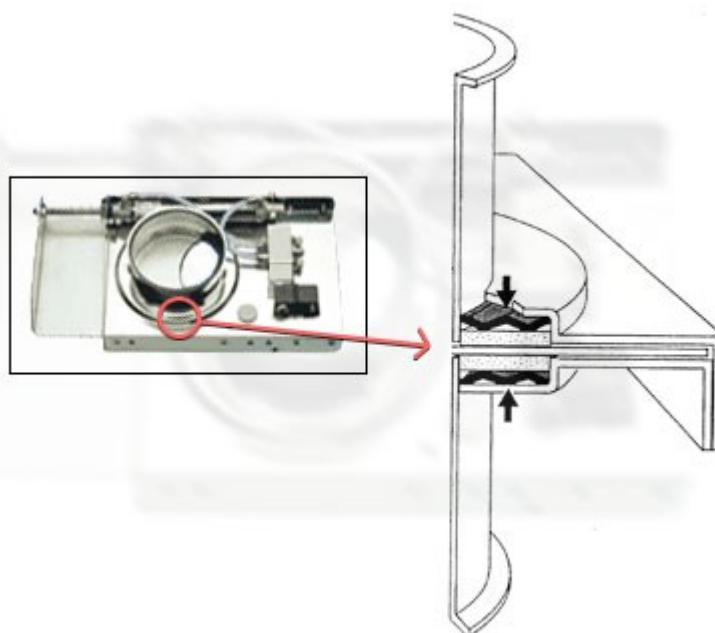

### **3. Use**

The slide valve is used for quick valving off of suction pipes.

For use as safety valve, i. e. barrier for fire areas, or for application in explosion-proof zones the valve is not suitable.

Operation in excess pressure, i. e. in transport pipes is conditional.

Installation outdoors bears the risk of passing below the dew-point.

This will lead to damage of the pneumatics.

At any rate the slide valve must be protected against any precipitation.

If necessary, suitability has to be tested by separate experiment!

### **4. Installation**

Zero-potential installation is absolutely necessary to prevent the valve from seizing.

The valve should not be installed flat, but as shown on the illustration below.

On installation with flanges please do not pull apart the shell.

This might lead to leakages and squealing sounds.

To blow the valve constantly, do not install the valve directly for or after shell moulds, bends or contiguous on intake and outlet of ventilators.

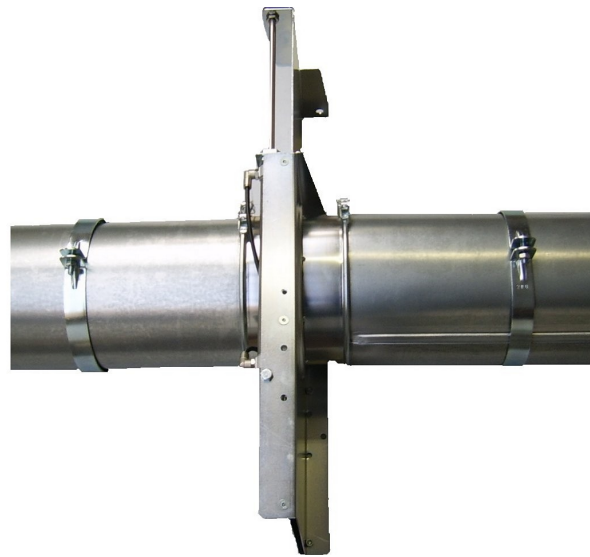

### **5. Maintenance**

All electric and pneumatic connections must be checked in intervals of four weeks at the latest and before putting into service.

Furthermore it has to be checked that all screws at shell, cylinder and piston rod fit properly.

The external nut of the piston rod is prevented from self-loosening by gluten or lacquer.

In case the nut is removed or released the gluten or lacquer has to be applied again after assembling.

## **6. Technical data**

Voltage: 24 V DC 3W or 220 V AC  
Please ask for further voltage.

Compressed air supply: 6 mm connector "push-in"

Pressure: maximum 9 barometric pressure

Operation: 5/2 sector with spring reset  
Valve is shut when electroless.

Opening and closing speed of the valve can be adjusted with the exhaust throttle.  
From a diameter of 280 mm the cylinder is equipped with an adjustable extreme position damper.

## 8. Spare part list

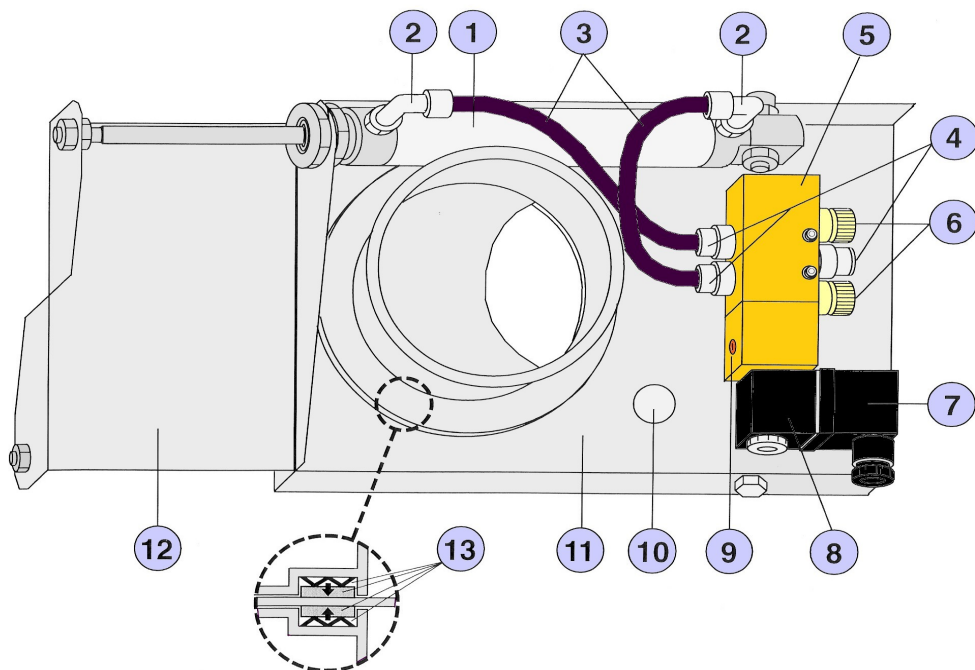

positon	designation
1	pneumatic cylinder
2	rotating edge connector 1/8 " for tube 6 x 4 mm
3	PUR-tube 6 x 4 mm, length 1 m
4	straight connector 1/8" for tube 6 x 4 mm
5	5/2 selector valve (without coil)
6	sound absorber for outgoing air throttle 1/8"
7	electrical connector DIN 43650
8	coil 230 V AC or 24 A DC (special voltages available)
9	additional manual operation
10	opening for limit switch type OEM
11	shell
12	slide valve sheet
13	sealing set for slide valve, diameter up to 200 mm
13	sealing set for slide valve, diameter form 225 mm up
	limit switch "Reed"
	saftey bars