

Product:	Fan unit - ZWR-05 2,2kW	
Index:	W0350ZWR05	302-30-0001

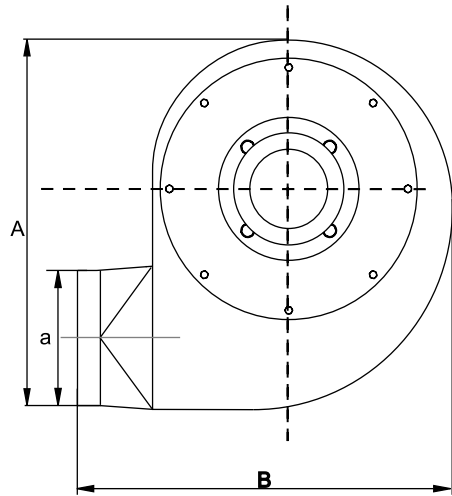

- A - 651
- B - 692,6
- H - 431,5
- a - 198
- b - 152
- d1 - 200
- d3 - 8x0,35

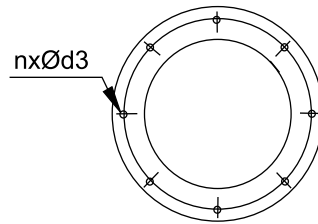
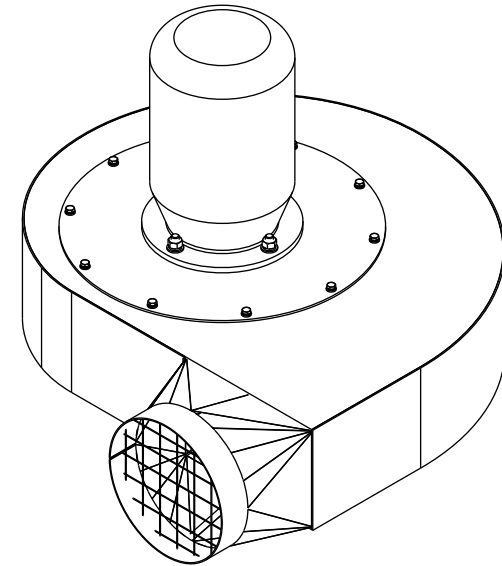
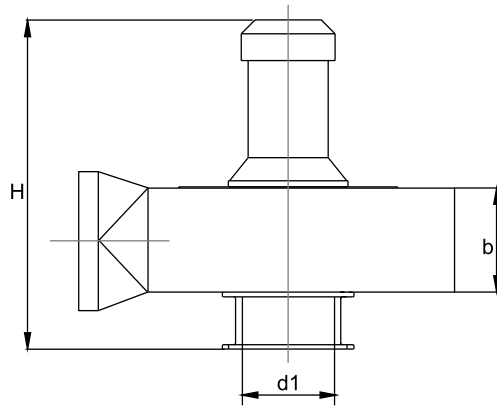

- Motor:**
- Power supply [V] / [Hz] - 3x400/50
 - Power [kW] - 2,2
 - Rotation [rpm] - 2800
 - Insulation class - F
 - Protection - IP55

with WS200 wall mounting brackets

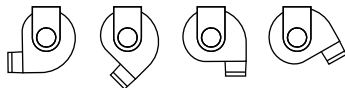

- Accessories and options:**
- P07-01-0005 - Mounting bracket Ø200
 - 100 044 - Motor on/off switch with thermal overload protection 4-6,3A
 - 230 016 - Set of transport wheels ZWR

- ZWR fan units :**
- backward inclined blade aluminum fan wheels
 - smooth fan and impeller inlets
 - powder coated welded steel housing
 - direct gas mixture temperatures up to 40°C

